

Introduction to data visualization with R

Andrew Heiss, PhD
Brigham Young University
SLC RUG • July 11, 2018
@andrewheiss

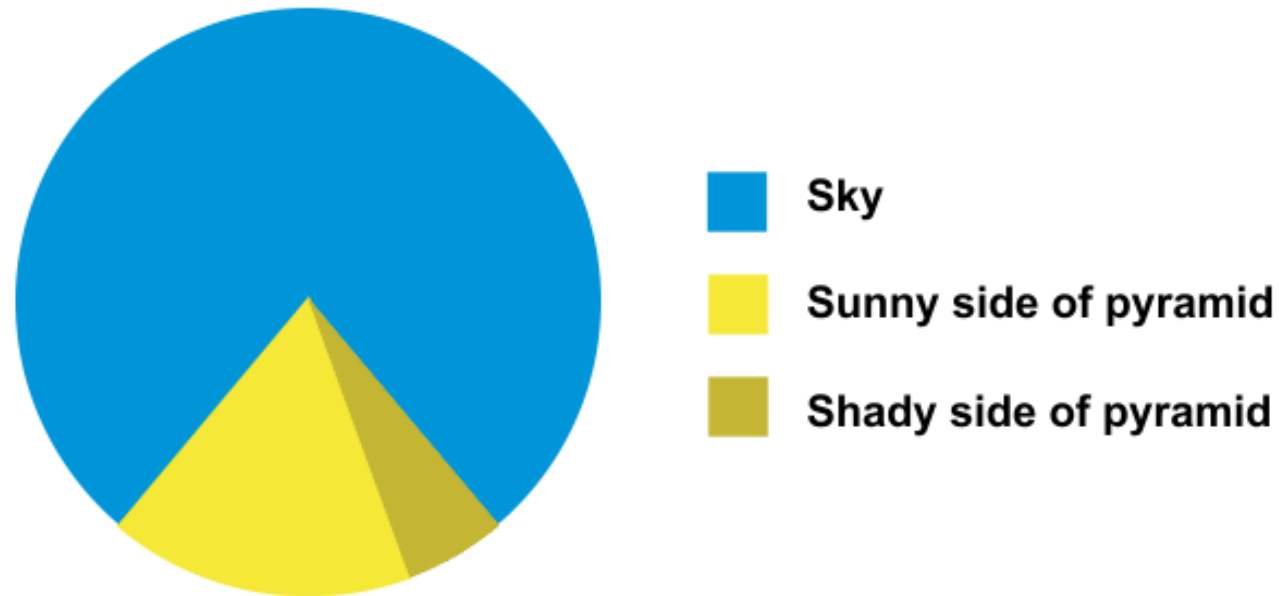

Plan for today

Why visualize data?

Types of visualizations

Aesthetics and design

 Take a sad plot and make it CRAPier 

talks.andrewheiss.com/utah-rug-dataviz/

111 Now that we know the quickity of truth through our knowledge of its definitions, let us learn the quality of truth, or how truth exists, and how it occurs and comes to be. We say that truth is a proposition with which the speaker's soul is tranquil,¹⁰ knowing that what he said is indeed <as he said it> and that what he described is indeed as he described it. We also say that the truth is a proposition that the tongue articulates, whereby the soul informs another soul regarding something of which like, *lateral* is *lesser* or of which it is *content*, in knowing.¹¹

10 وَهُوَ مَا نَعِيَ الْقَلْبَ بِعَرَفَتِهِ "سوره" "تعرّف الأن كقوله الخ. أو كيف يكون الخ ويصح
ويصح. وتقول إن الخ حلال لشك إليه النفس بعلها" "إن ما نقله كما قال" وما وصف كما وصف
وتقول أيضًا: إن الخ حلال بخلق به اللسان محرم "أرضي النفس لا تتطاع نفس أخرى في ما جهلت أو
سكنت" وتقول أيضًا: إن الخ حروب تحكي "صورة الموجودات بوجود المتفرقات. وتقول أيضًا: إن

THE FIRST BOOK OF NEPHI

His Reign and Ministry

An account of Lehi and his wife Sarah, and his four sons, being called, (beginning at the eldest) Laman, Lemuel, Sam, and Nephi. The Lord warns Lehi to depart out of the land of Jerusalem, because he prophesieth unto the people concerning their iniquity and they seek to destroy his life. He taketh three days' journey into the wilderness with his family. Nephi taketh his brethren and rebueth to the land of Jerusalem after the record of the Jews. The account of their sufferings: They take the daughters of Ishmael to wife. They take their families and depart into the wilderness. Their sufferings and afflictions in the wilderness. The course of their travels. They come to the large waters. Nephi's brethren rebel against him. He confoundeth them, and buildeth a ship. They call the name of the place "Bountiful." They cross the large waters into the promised land, and so forth. This is according to the account of Nephi; or, in other words, I, Nephi, wrote this record.

Nephi's Introduction

[1] I, Nephi, having been born of goodly¹ parents, therefore I was taught somewhat in all the learning of my father; and having seen many afflictions in the course of my days, nevertheless, having been highly favoured of the Lord in all my days, yea, having had a great knowledge of the goodness and the mysteries of God, therefore I make a record of my proceedings in my days.² Yea, I make a record in the language of my father, which consists of the learning of the Jews and the language of the Egyptians.³ And I know that the record which I make is true; and I make it with my own hands; and I make it according to my knowledge.

Lehi's Commission

"For it came to pass in the commencement of the first year of the reign of Zedekiah,⁴ king of Judah, (my father, Lehi, having dwelt at Jerusalem in all his days); and in that same year there came many prophets, prophesying unto the people that they must repent, or the great city Jerusalem must be destroyed.⁵ Wherefore it came to pass that my father, Lehi, as he went forth prayed unto the Lord, yea, even with all his heart, in behalf of his people.⁶ And it came to pass as he prayed unto the Lord, there came a pillar

of fire and dwelt upon a rock before him; and he saw and heard much; and because of the things which he saw and heard he did quake and tremble exceedingly.

⁷And it came to pass that he returned to his own house at Jerusalem; and he cast himself upon his bed, being overcome with the Spirit and the things which he had seen.⁸ And being thus overcome with the Spirit, he was carried away in a vision, even that he saw the heavens open, and he thought he saw God sitting upon his throne, surrounded with countenanceless concourses of angels in the attitude of singing and praising their God.⁹

¹⁰And it came to pass that he saw One descending out of the midst of heaven, and he beheld that his lustre was above that of the sun at noon-day.¹¹ And he also saw twelve others following him, and their brightness did exceed that of the stars in the firmament.¹² And they came down and went forth upon the face of the earth; and the first came and stood before my father, and gave unto him a book, and bade him that he should read.¹³ And it came to pass that as he read, he was filled with the Spirit of the Lord.

¹⁴And he read, saying, "Woe, woe, unto Jerusalem, for I have seen thine abominations!" Yea, and many things did my father read concerning Jerusalem—that it should be destroyed, and the inhabitants thereof; many should perish by the sword, and many should be carried away captive into Babylon.

¹⁵And it came to pass that when my father had read and seen many great and marvelous things, he did exclaim many things unto the Lord, such as:

"Great and marvelous are thy works, O Lord God Almighty!

Thy throne is high in the heavens,
and thy power, and goodness, and mercy
are over all the inhabitants of the earth.

And because thou art merciful,
thou wilt not suffer those who come unto thee
that they shall perish."

¹⁶And after this manner was the language of my father in the praising of his God; for his soul did rejoice, and his whole heart was filled, because of the things which he had seen, yea, which the Lord had shown unto him.

¹⁷And now I, Nephi, do not make a full account of the things which my father hath written, for he hath written many things which he saw in visions and in dreams; and he also hath written many things which he prophesied and spake unto his children, of which I shall not make a full account.¹⁸ But I shall make an account of my proceedings in my days. Behold, I make an abridgment of the record of my father, upon plates which I have made with mine own hands; wherefore, after I have abridged the record of my father then will I make an account of mine own life.

¹ Roman numerals indicate the original *also* chapter breaks, which appear to have been part of the record on the gold plates. The current chapter numbers, added in *italy*, are in *italics* numerals.

² *True godly*.

³ *See 1st Nephi*.

⁴ The twenty-one words "see God . . . praising their God" are quoted exactly at *Alma 1:1-4*.

⁵ Both *we* and the standard spelling *we* occur in the Book of Mormon.

⁶ Or: *concerning Jerusalem that it should be destroyed, and its inhabitants thereof . . . many should*



Global Water Crisis Fact Sheet

Global Water Crisis

- There are 1.1 billion people, or 18% of the world's population, who lack access to safe drinking water.
- In Africa alone, people spend 40 billion hours every year just walking for water
- Unsafe water and lack of basic sanitation cause 80% of diseases and kill more people every year than all forms of violence, including war.
- 50% of all schools in the world don't have access to clean, safe water
- The average person in a developing nation struggles to find 5 gallons of water a day.
- Each year 443 million school days are lost due to lack of clean water and sanitation
- 4,500 children will die today from water related diseases
- At any one time, half of the world's hospital beds are occupied by patients suffering from water-borne diseases.



Kenya's Water Crisis

Kenya is classified by the United Nations as a chronically water-scarce country.

A water-stressed nation has a per-capita freshwater supply of 1,000-1,700 m³; a water-scarce country on the other hand, has less than 1,000 m³ per capita. Kenya's natural water endowment is 647 m³ per capita.

Shortage of Clean Water

- The 2006 drought in Kenya was declared a national disaster, as 3.5 million people faced starvation and food shortages.
- 41% of 29.8 million Kenyans do not have access to clean water.
- Droughts continue to plague the region. Beyond the threat of drought-induced food scarcity, 10% of deaths in Kenya occur from water-borne or sanitation-related diseases.

Insufficient Household Drinking Water

- In 49% of all Kenyan households, women are in charge of water collection.
- In 58% of rural Kenyan households, women are in charge of water collection.
- 46% of rural households get water from non-improved sources (mainly surface water from lakes, streams, rivers).
- Only 45% of Kenyans treat their drinking water.

How You Can Help

Quiet Way can ensure accessible and sustainable clean water for people with the generous support of donors like you. Donations of all sizes are used to improve the lives of millions of Kenyans, and to build a successful water resource management model that can spread across the developing world.

- To donate, please visit quietway.org



quietway.org | 801-669-7583 | 1105, Main, Lindon, UT 84042

Figure 7: Life expectancy plotted by governance

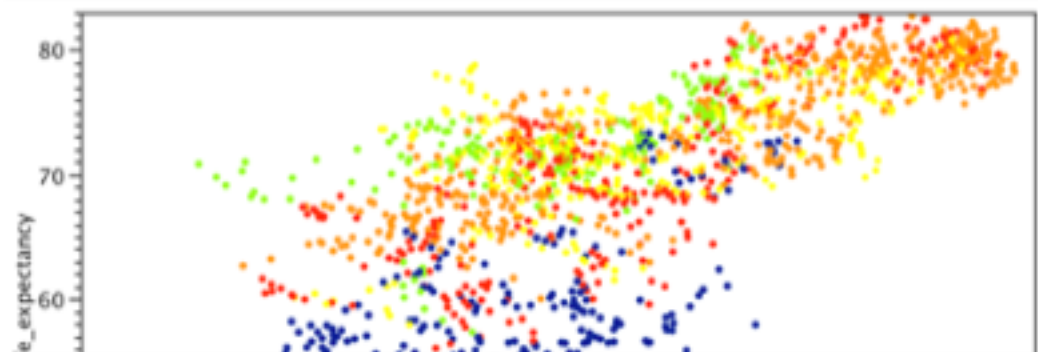

Winners from Nathan's Hot Dog Eating Contest

Since 1916, the annual eating competition has grown substantially attracting competitors from around the world. This year's competition will be televised on July 4, 2008 at 12pm EDT live on ESPN.

70 Hot dogs and buns (HDBs)

NEW WORLD RECORD



For the first time since 1999, an American reclaims the title when **Joey Chestnut** consumes 66 HDBs, a new world record.



Through 2001-2005, **Takeru Kobayashi** wins by no less than 12 HDBs. In 2006, he only wins by 1.75. After winning 6 years in a row and setting the world record 4 times, Kobayashi places second in 2007.

Frank Dellarosa eats 21 and a half HDBs over 12 minutes, breaking the previous record of 19 and a half.

Walter Paul sets a new world record with 17 HDBs.

James Mullen wins the inaugural contest, scarfing 13 HDBs. Length of contest is unavailable.



Data between 1916 and 1972 were unavailable

Source: Wikipedia and Nathan's Famous

FlowingData

NATHAN YAU

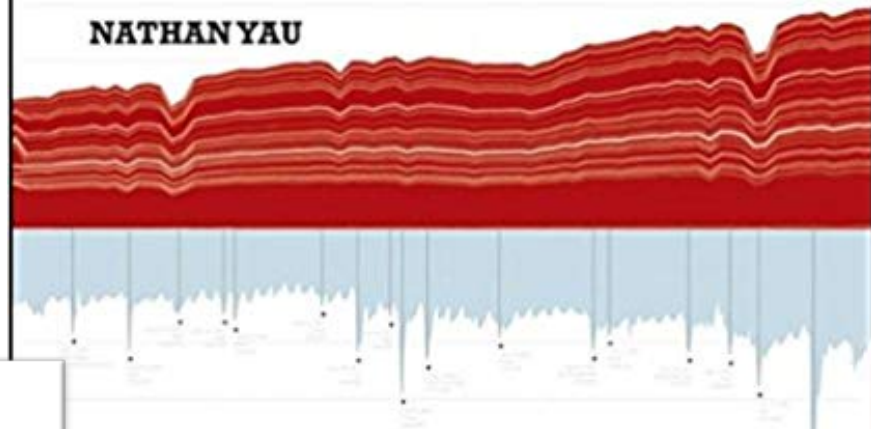

VISUALIZE THIS

The FlowingData Guide to Design, Visualization, and Statistics

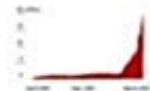
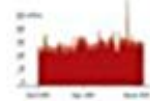

Why visualize data?

**Data alone cannot tell
stories or prove theories**

	I		II		III		IV	
	x	y	x	y	x	y	x	y
	10	8,04	10	9,14	10	7,46	8	6,58
	8	6,95	8	8,14	8	6,77	8	5,76
	13	7,58	13	8,74	13	12,74	8	7,71
	9	8,81	9	8,77	9	7,11	8	8,84
	11	8,33	11	9,26	11	7,81	8	8,47
	14	9,96	14	8,1	14	8,84	8	7,04
	6	7,24	6	6,13	6	6,08	8	5,25
	4	4,26	4	3,1	4	5,39	19	12,5
	12	10,84	12	9,13	12	8,15	8	5,56
	7	4,82	7	7,26	7	6,42	8	7,91
	5	5,68	5	4,74	5	5,73	8	6,89
SUM	99,00	82,51	99,00	82,51	99,00	82,50	99,00	82,51
AVG	9,00	7,50	9,00	7,50	9,00	7,50	9,00	7,50
STDEV	3,32	2,03	3,32	2,03	3,32	2,03	3,32	2,03

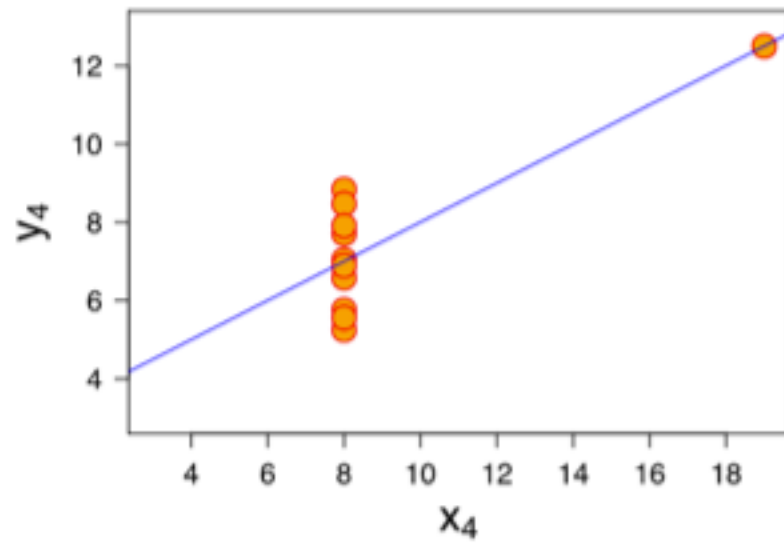
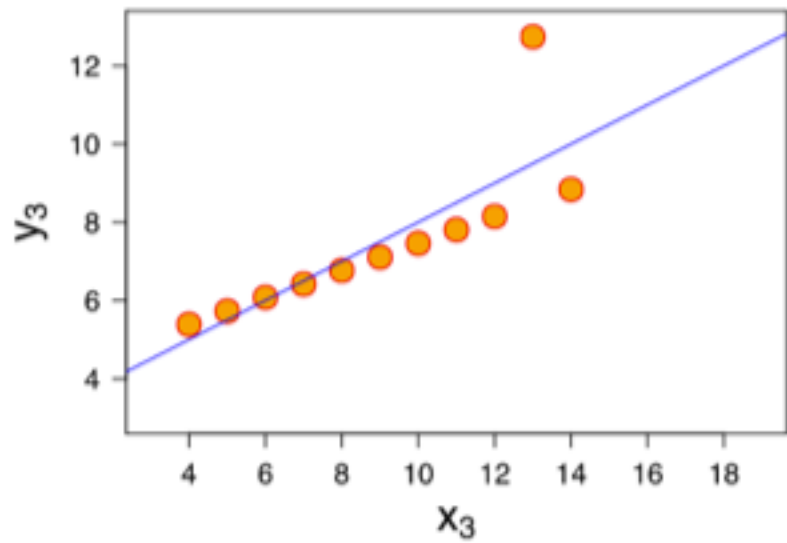
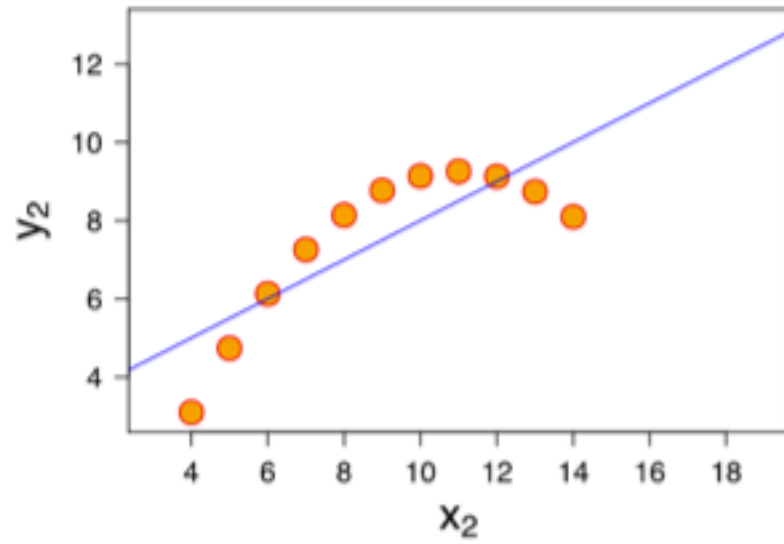
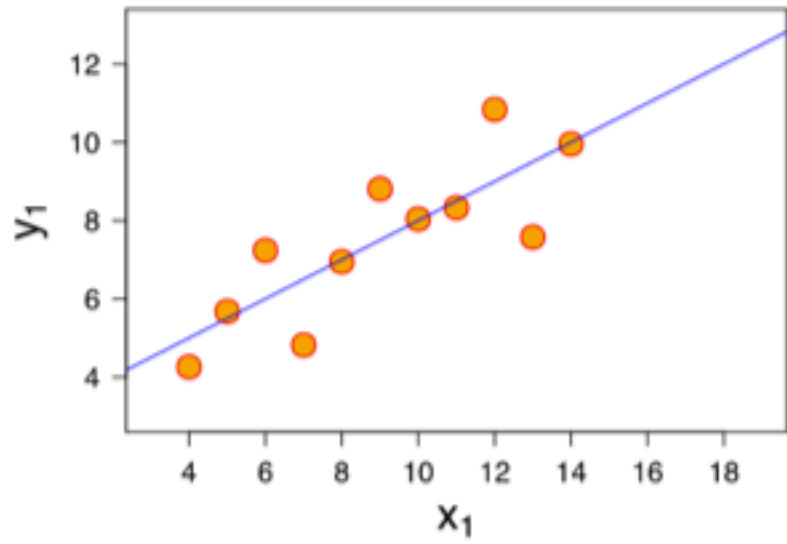

Never trust summary statistics alone

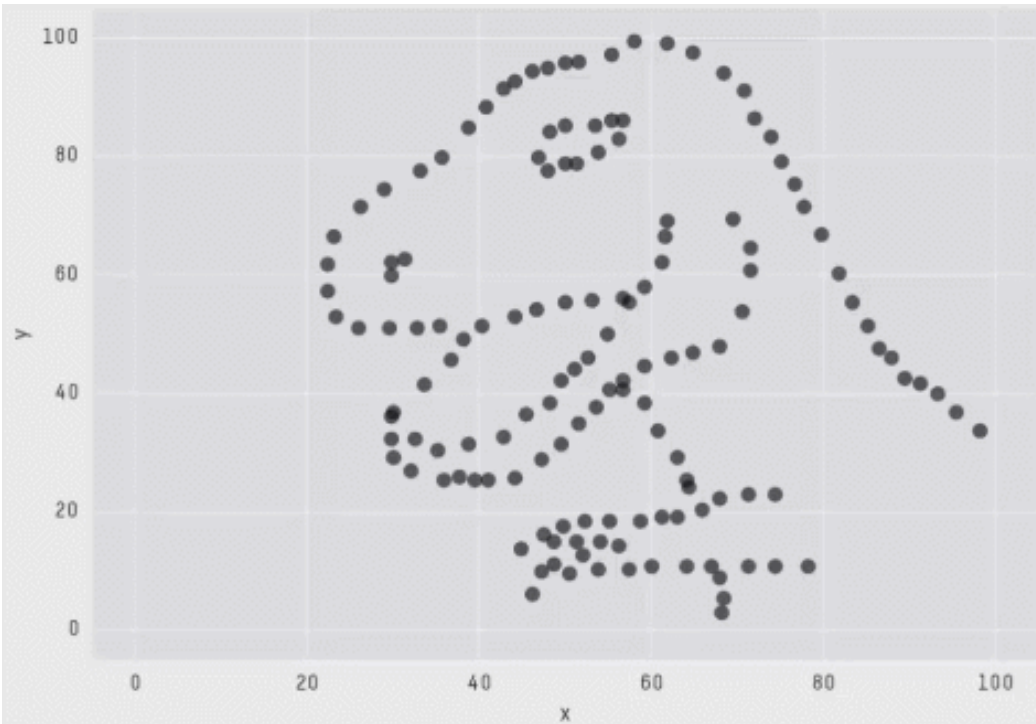

X Mean: 54.2659224
Y Mean: 47.8313999
X SD : 16.7649829
Y SD : 26.9342120
Corr. : -0.0642526

Humans are visual creatures

frontiers in
NEUROSCIENCE

REVIEW ARTICLE
published: 22 August 2014
doi: 10.3389/fnins.2014.00265



Superior pattern processing is the essence of the evolved human brain

Mark P. Mattson^{1,2*}

¹ Laboratory of Neurosciences, National Institute on Aging Intramural Research Program, Baltimore, MD, USA
² Department of Neuroscience, Johns Hopkins University School of Medicine, Baltimore, MD, USA

Edited by:
J. Michael Williams, Drexel
University, USA

Humans have long pondered the nature of their mind/brain and, particularly why its capacities for reasoning, communication and abstract thought are far superior to other species, including closely related anthropoids. This article considers superior pattern

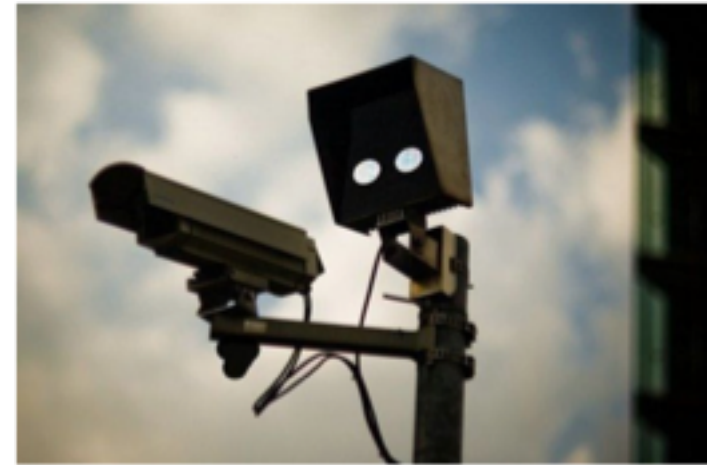
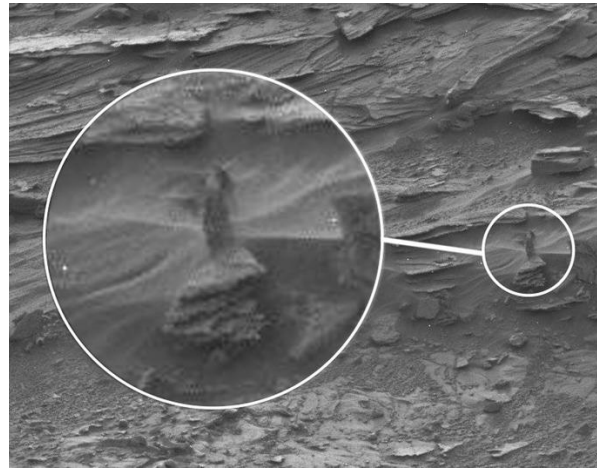
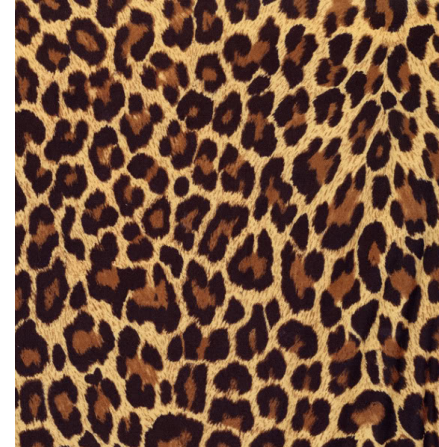

@FacesPics

	(1)	(2)	(3)	(4)	(5)	(6)
Intercept	20.207	20.641	22.033	4.374	4.240	6.146
Crackdown (yes)	(1.597)	(2.239)	(3.049)	(4.5)		
Issue (humanitarian)	3.797	2.636	-2.692	3.1		
	(2.254)	(3.055)	(4.337)	(2.1)		
Funding (private)		-0.993	-4.030			
		(3.094)	(4.312)			
Crackdown × Issue			-2.867			
			(4.444)			
Crackdown × Funding		2.418	15.090			
		(4.366)	(5.969)			
Issue × Funding			10.831			
			(6.274)			
Crackdown × Issue × Funding			6.595			
			(6.013)			
Prior favorability towards humanitarian NGOs			-25.544			
			(8.628)			
Give to charity once a month–once a year			1.2			
			(3.6)			
Give to charity at least once a month			8.6			
			(3.1)			
Volunteered in past year			7.4			
			(3.0)			
Follow current political evens often			5.4			
			(2.2)			
Liberal political views			8.2			
			(2.7)			
Bachelor's degree or higher			2.3			
			(2.4)			
Attend religious services at least once a month			9.817	9.833	9.230	
			(2.2)	(2.2)	(2.2)	

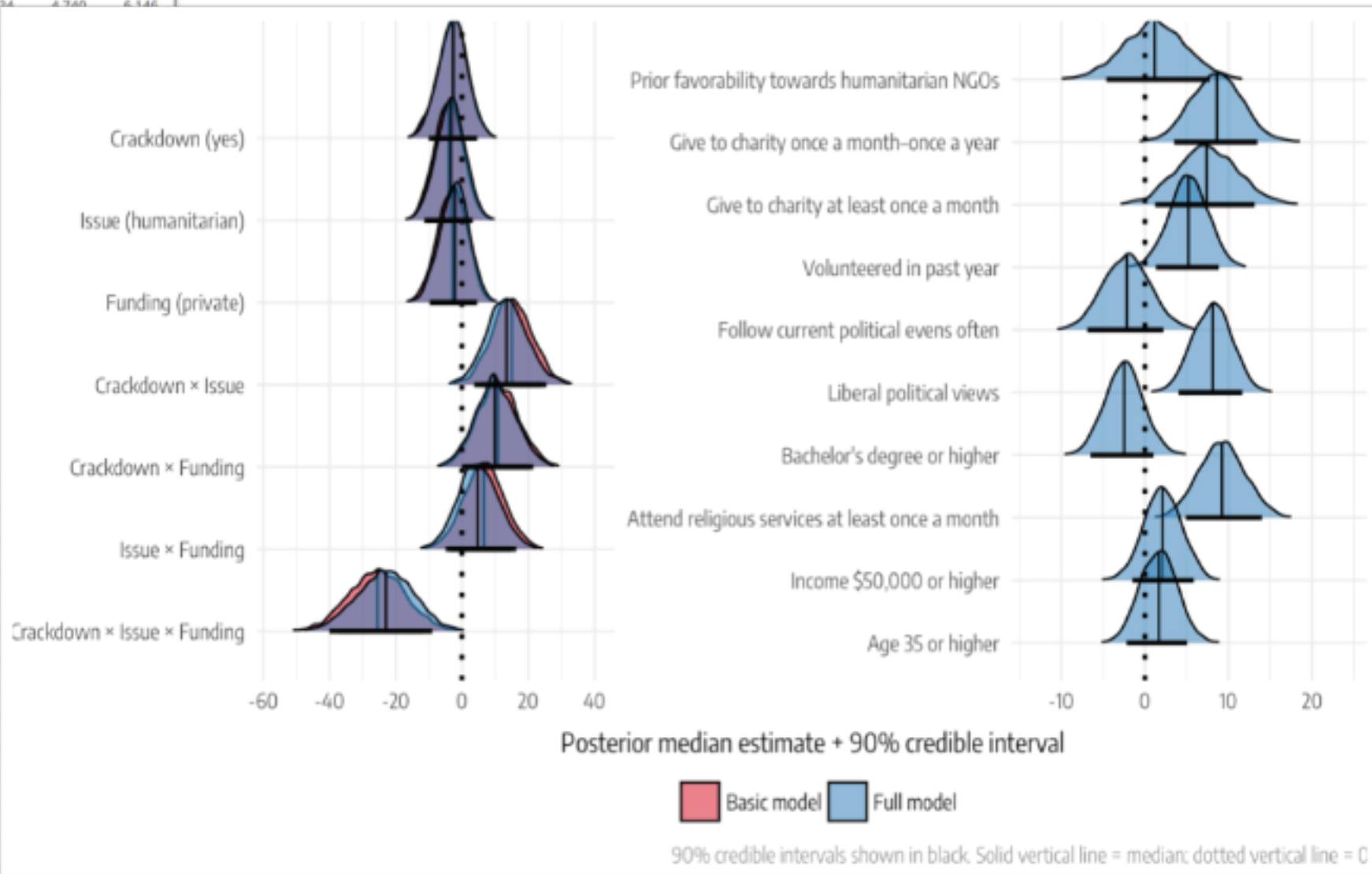

**What makes a good
visualization?**

Carte Figurative des pertes successives en hommes de l'Armée Française dans la campagne de Russie 1812-1813.

Dressée par M. Minard, Inspecteur Général des Ponts et Chaussées en retraite Paris, le 20 Novembre 1869.

Les nombres d'hommes présents sont représentés par les largeurs des zones colorées à raison d'un millimètre pour dix mille hommes; ils sont de plus écrits en travers des zones. Le rouge désigne les hommes qui entrent en Russie, le noir ceux qui en sortent. — Les renseignements qui ont servi à dresser la carte ont été puisés dans les ouvrages de M. M. Chiers, de Ségur, de Fezensac, de Chambray et le journal inédit de Jacob, pharmacien de l'Armée depuis le 28 Octobre. Pour mieux faire juger à l'œil la diminution de l'armée, j'ai supposé que les corps du Prince Jérôme et du Maréchal Davout qui avaient été détachés sur Minsk et Mohilow et ont rejoint vers Orscha et Witebsk, avaient toujours marché avec l'armée.



TABLEAU GRAPHIQUE de la température en degrés du thermomètre de Réaumur au dessous de zéro.

Les Cosaques passent au galop le Niémen gelé.

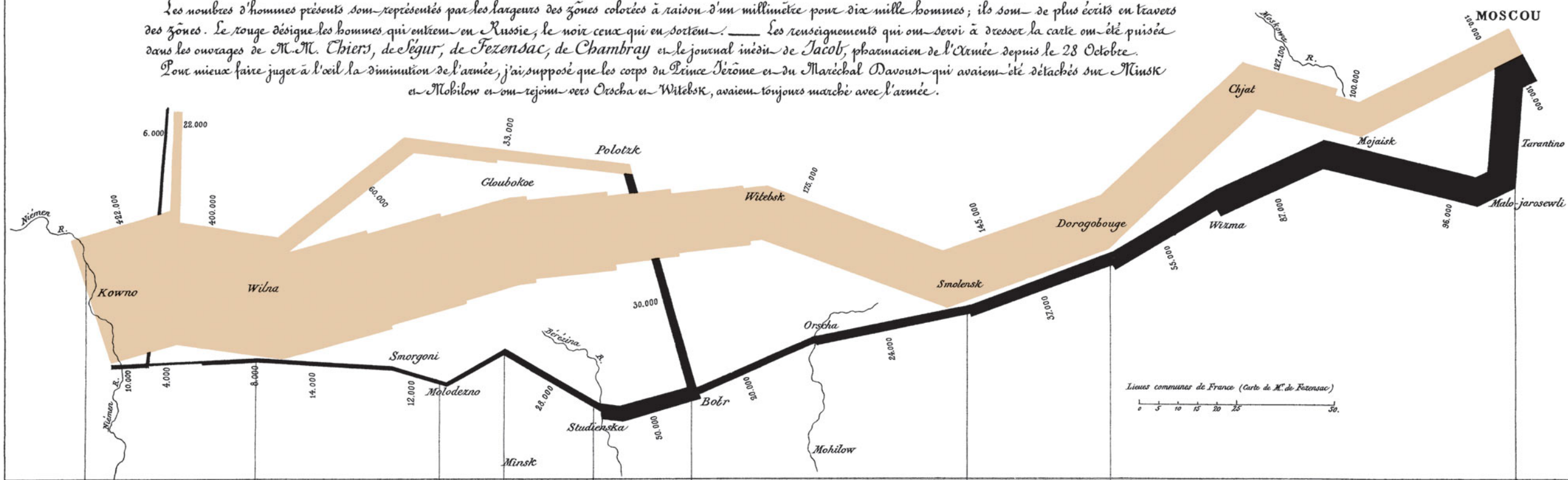
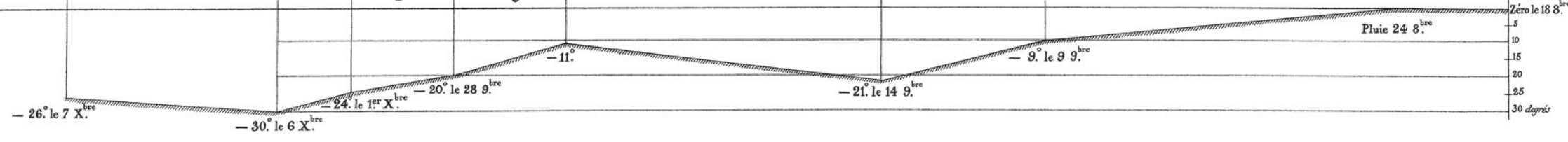

Characteristics of graphical excellence

1. "... the well-designed presentation of interesting data—a matter of substance, statistics, and design."

2. Complex ideas communicated with clarity, precision, and efficiency.

3. That which gives the viewer the greatest number of ideas in the shortest time with the least ink in the smallest space.

4. Nearly always multivariate.

5. Requires telling the truth about the data.

What makes Minard's graph so great?

$$\text{Data:Ink ratio} = \frac{\text{Ink}_{\text{Data}}}{\text{Ink}_{\text{Total}}}$$

We forget this!

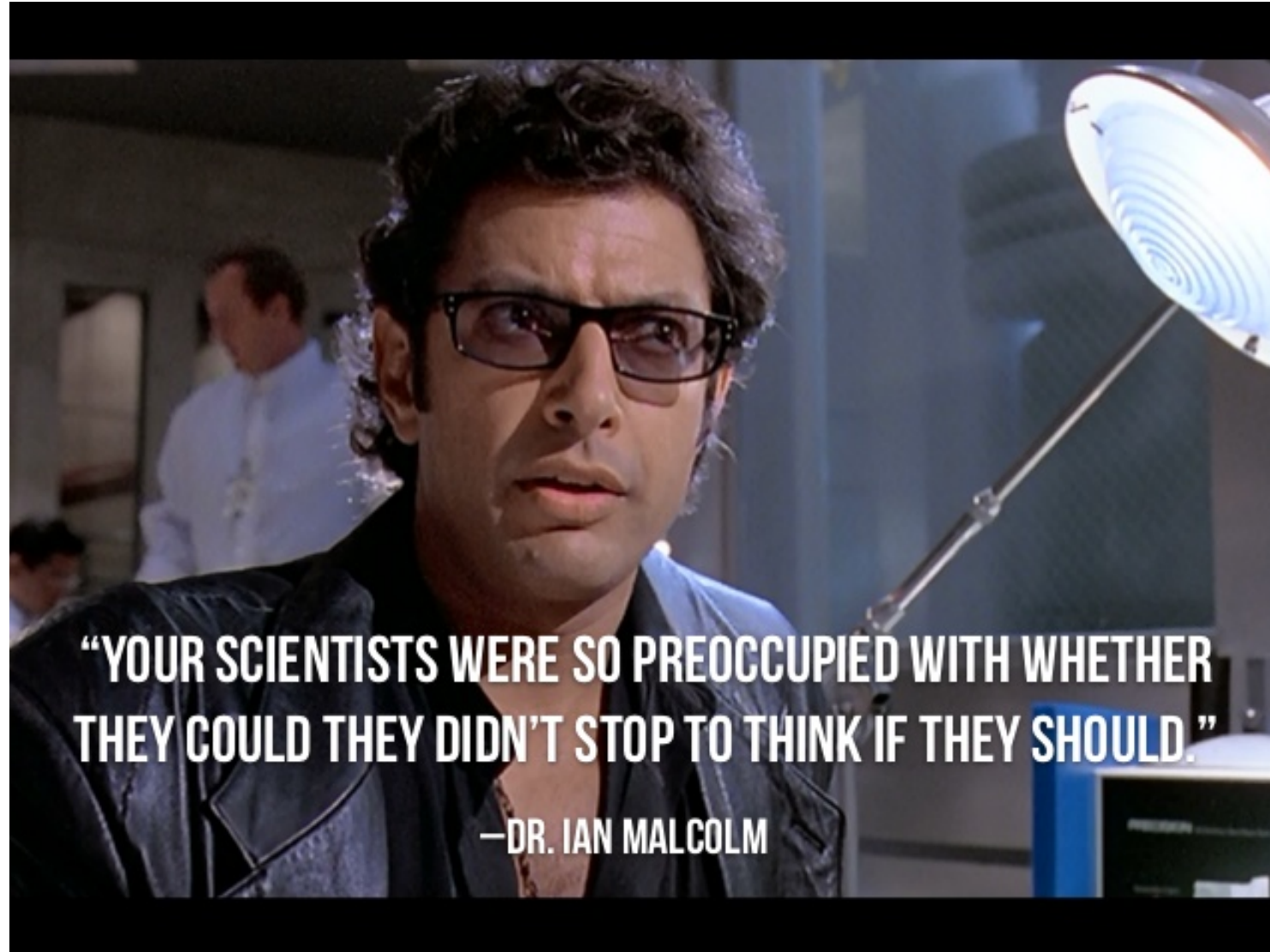

“YOUR SCIENTISTS WERE SO PREOCCUPIED WITH WHETHER THEY COULD THEY DIDN'T STOP TO THINK IF THEY SHOULD.”

—DR. IAN MALCOLM

(f) Distribution of Genus

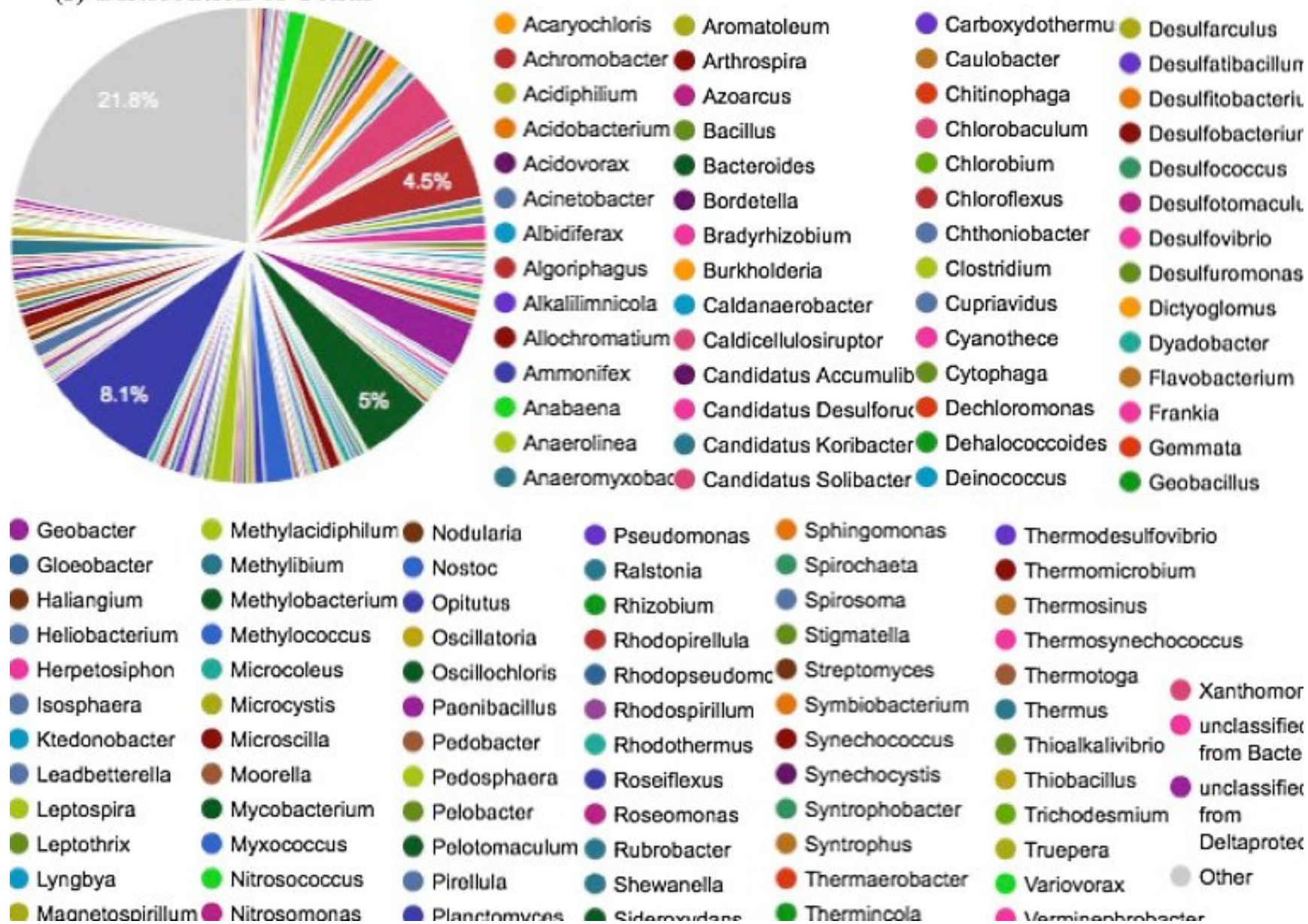

CHANGING FACE OF AMERICA

Percent of total U.S. population by race and ethnicity, 1960-2060

1960

2010

2060

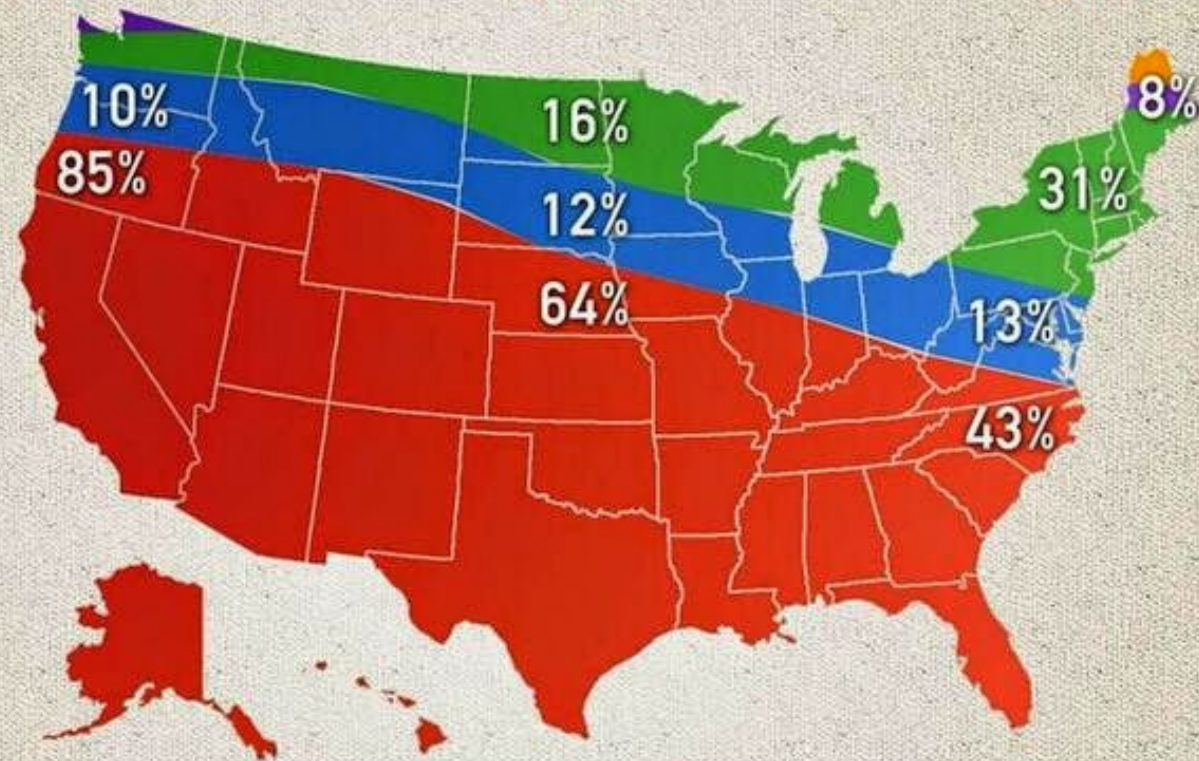

OTHER

ASIAN

HISPANIC

BLACK

WHITE

SOURCE: PEW RESEARCH CENTER

NIGHTLY NEWS
with BRIAN WILLIAMS

Types of visualizations

Exploratory visualizations

Academic-ish

Quick scatterplots, histograms, other charts to help understand your data

Explanatory visualizations

Publishable

Consumable by the general public; Vox, NYT, Washington Post, FiveThirtyEight, etc.

Exploratory data analysis

Find analytical insight in data (even causal inference 🤖)

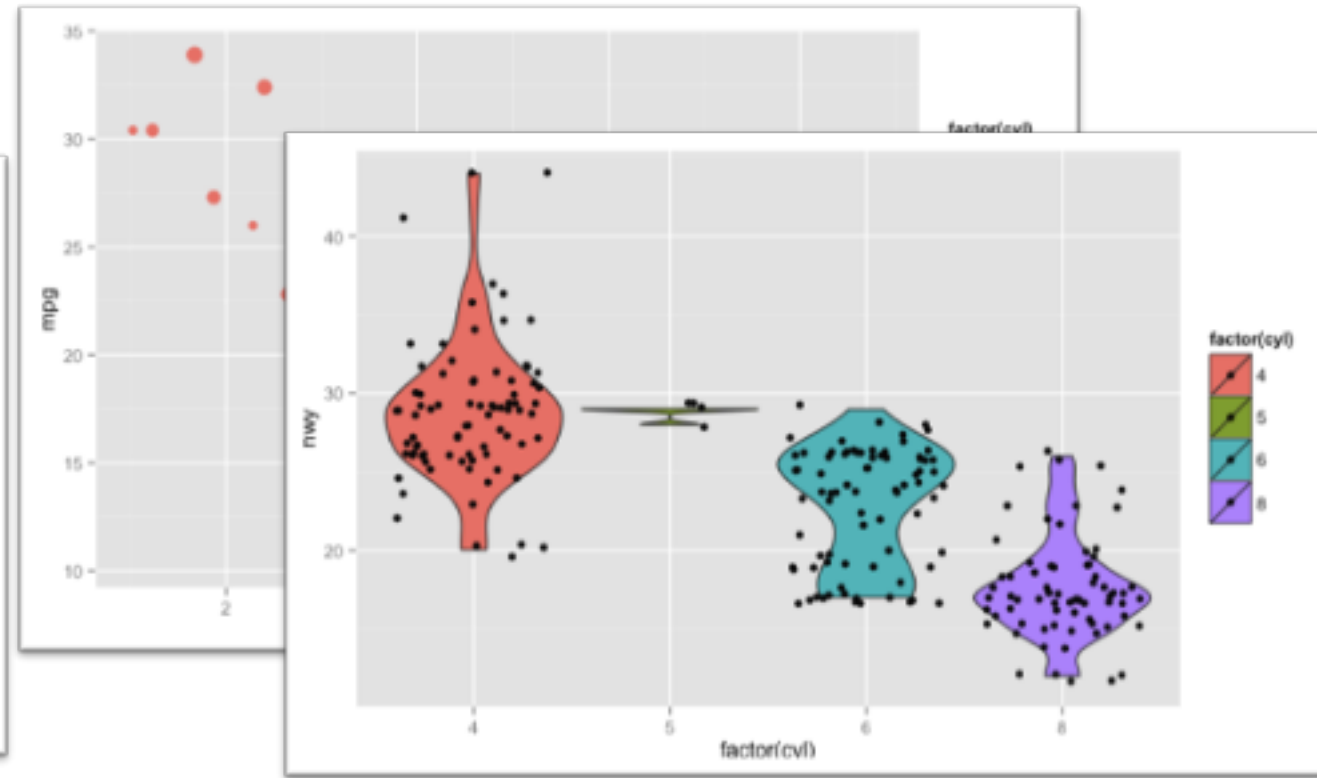
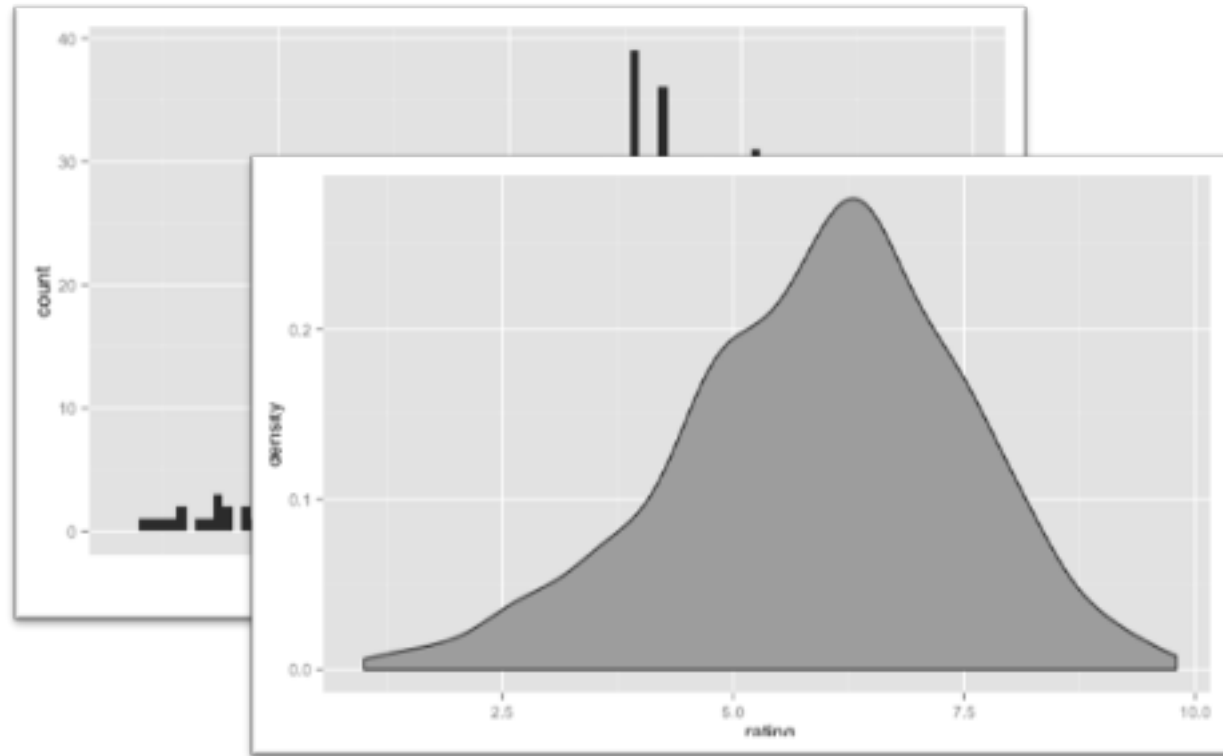

Explanatory data analysis

Annotate and tell a story

Republicans Shift to the Right, Democrats to the Left

Distribution of Republicans and Democrats on a 10-item scale of political values

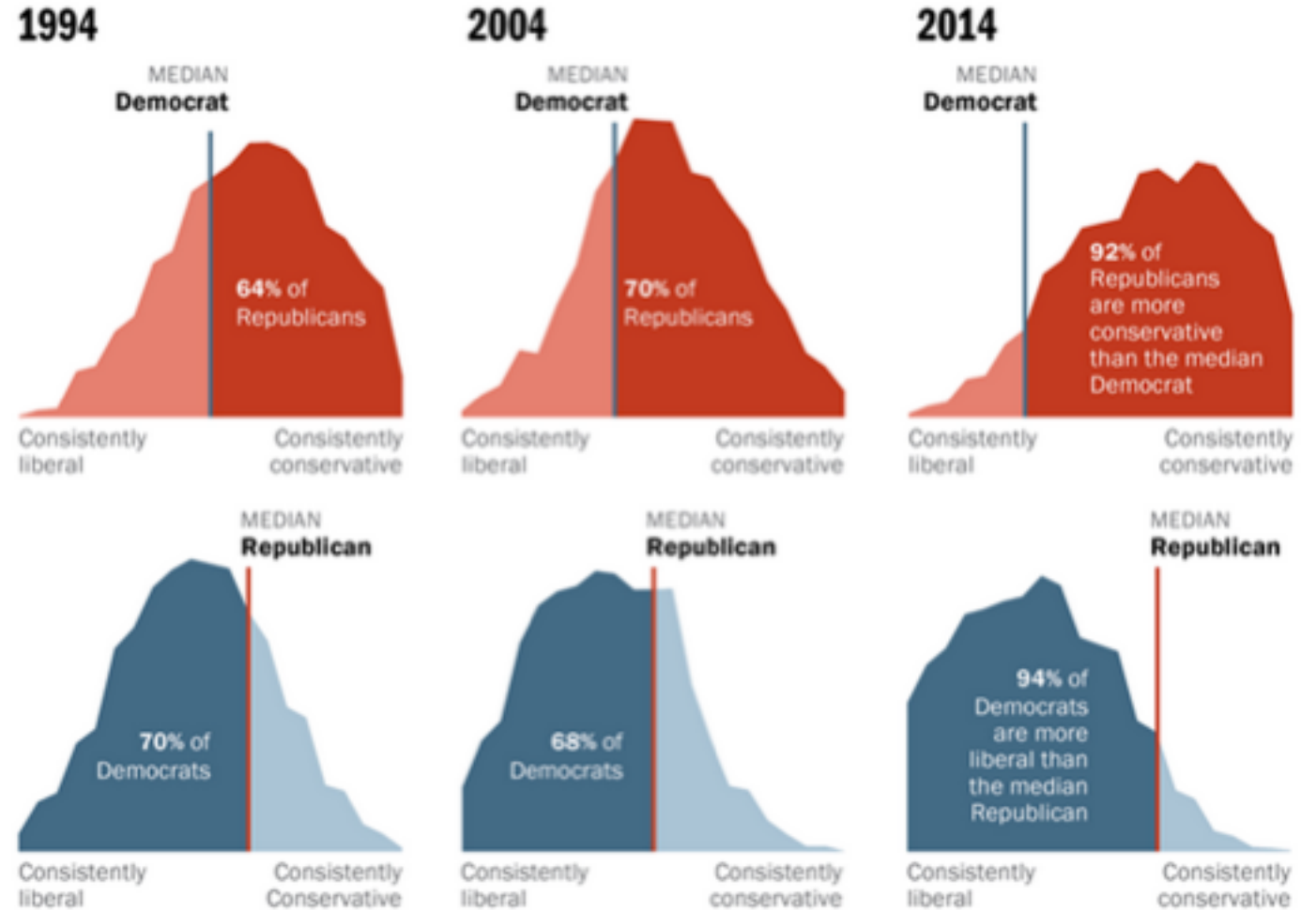

Source: 2014 Political Polarization in the American Public.

Notes: Ideological consistency based on a scale of 10 political values questions (see Appendix A). Republicans include Republican-leaning independents; Democrats include Democratic-leaning independents (see Appendix B).

PEW RESEARCH CENTER

Exploratory

Explanatory

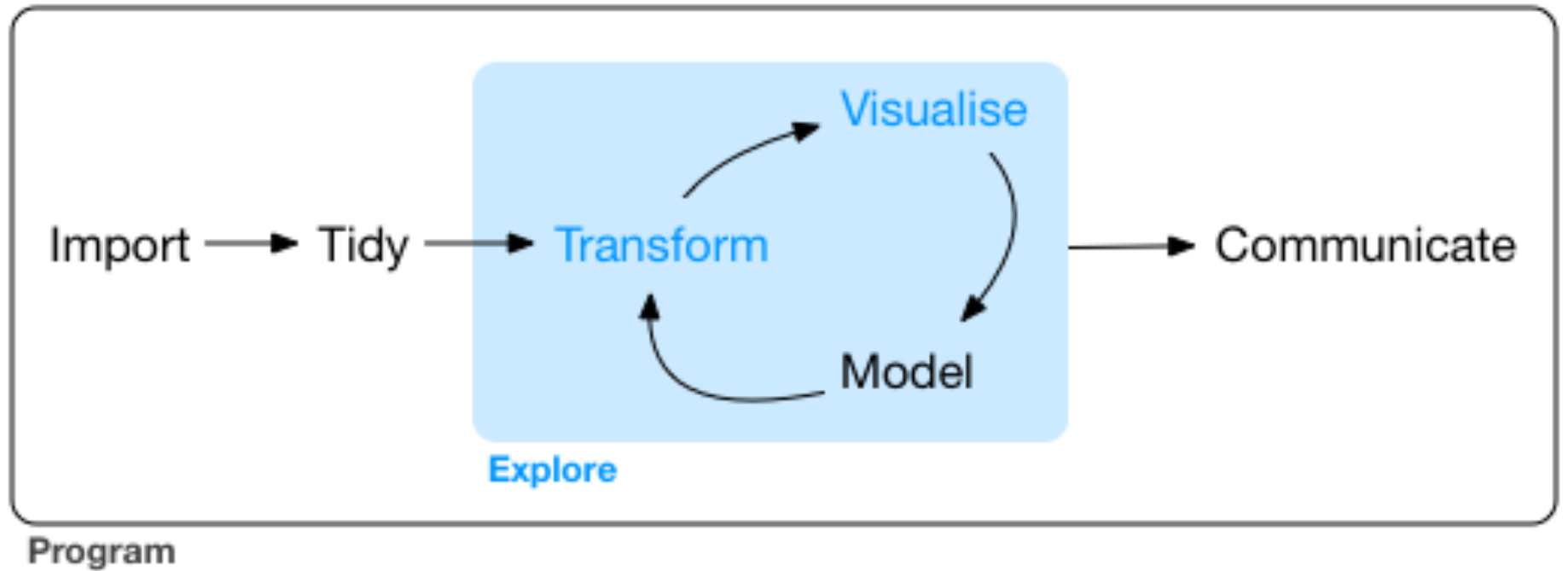

Which chart type do I use?

Numeric Categoric Num & Cat Maps Network Time series

Distribution

Filter by chart name or AKA

Reference Type: ○ Example ● Solution | Chart Families: ● Categorical ● Hierarchic

	Amazon QuickSight	ArcGIS	ChartJS	D3.js	Data Illustrator	Datawrapper	Flourish	FusionCharts	Gephi	Google Charts
Bar chart	●			●●●	○	●●●	○	○		●●
Clustered bar chart	●			●	○	●●●○	○	○		●●
Bullet chart				●		●●		○		
Connected dot plot				●●		●●○				

Aesthetics and design



Edward Tufte

@EdwardTufte



Following

#Rstats coders and users just can't do words on graphics and typography. Proof: 40 years of clunky, even recent Stanford Statistics textbooks. Publication-quality work requires: R + Adobe Illustrator + reasoning about words on graphics + respect for audience/readers/viewers <https://t.co/tqFYoZAH5v>



Reply



Retweet



Favorite



More

8:31 AM - 26 Jun 18 · Embed this Tweet



Claus Wilke

@ClausWilke



Sad to announce I'll have to abandon my project of writing a book on [#dataviz](#) entirely in [#rstats](#), with all figures programmatically generated. I just learned it is not possible. Ignore the 21 chapters already online. They are a mirage. serialmentor.com/dataviz/ [twitter.com/EdwardTufte/st...](https://twitter.com/EdwardTufte/status/1010000000000000000)

11:02 AM - Jun 26, 2018



Funda

A guide
reflect
serialm

♡ 753 💬 97 people are talking about this



Nihilist Data Scientist

@nihilist_ds



Most [#DataScience](#) folks eventually learn that while we all aspire to create [#dataviz](#) that meets Tufte's approval, we are all doomed to fall short under his watchful gaze.

So as with all other things in life it's healthier to give up. Embrace your failure, for it is inevitable.

3:56 PM - Jun 26, 2018

♡ 138 💬 33 people are talking about this



Is he maybe a little right?



```
plot(mtcars$wt, mtcars$mpg)
```

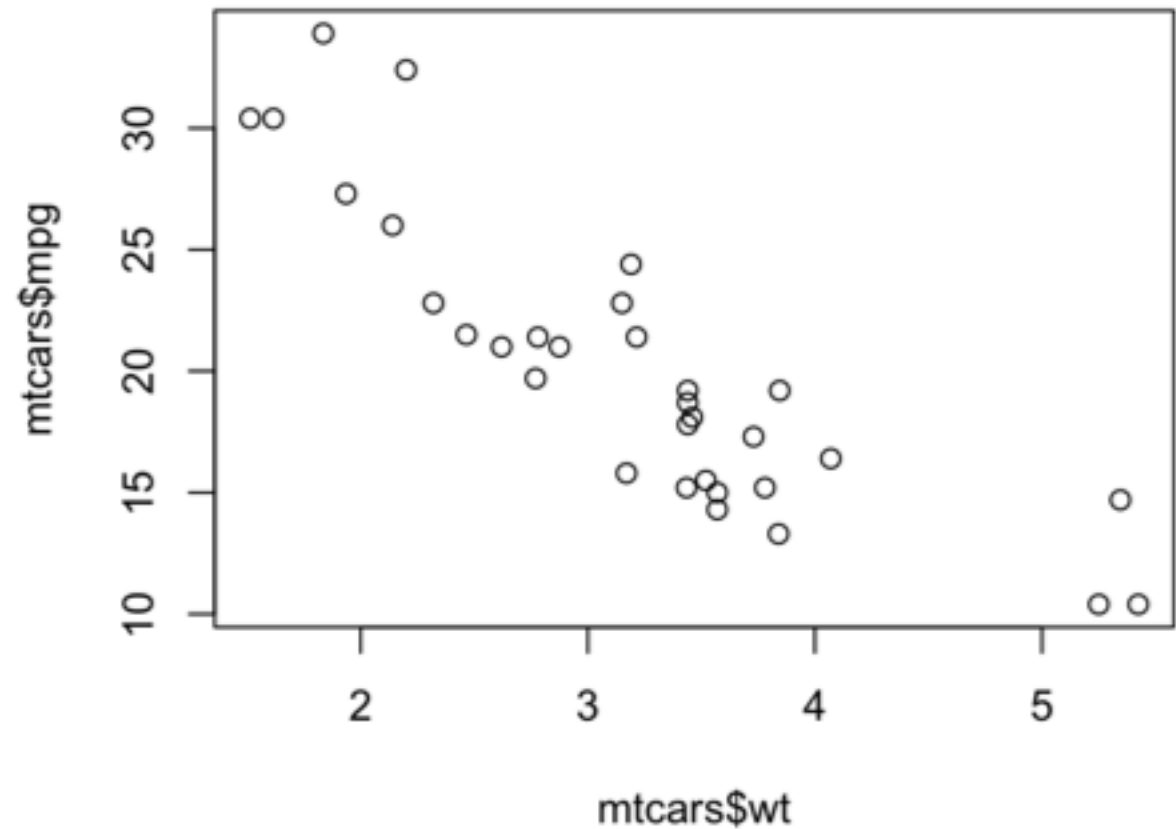

R can't do everything

There's still a place for
Illustrator, InDesign, et al.

1 2 3 4 5 6 7 8 9 10

1 2 3 4 5 6 7 8 9 10

1 2 3 4 5 6 7 8 9 10

1 2 3 4 5 6 7 8 9 10

The affluent official fly fished in cutoffs

The affluent official fly fished in cutoffs

**What constitutes
good design?**

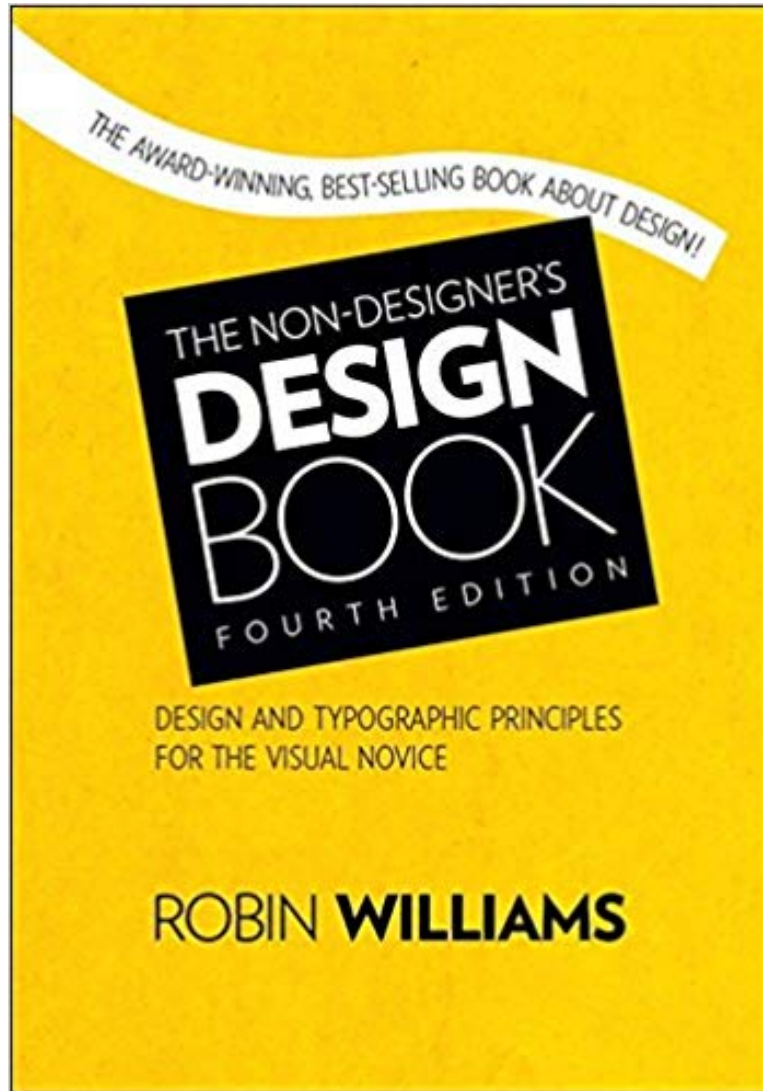

Four core design principles

Contrast

Repetition

Alignment

Proximity

Contrast

“If two items are not exactly the same, make them different. **Really different.**”

Don't be a wimp!

Serif

Lorem ipsum dolor sit amet

Sans Serif

Lorem ipsum dolor sit amet

Slab Serif

Lorem ipsum dolor sit amet

Script

Lorem ipsum dolor sit amet

Decorative

Lorem ipsum dolor sit amet

Light

Lorem ipsum dolor sit amet

Black

Lorem ipsum dolor sit amet



<https://color.adobe.com/>



<http://colorbrewer2.org/>

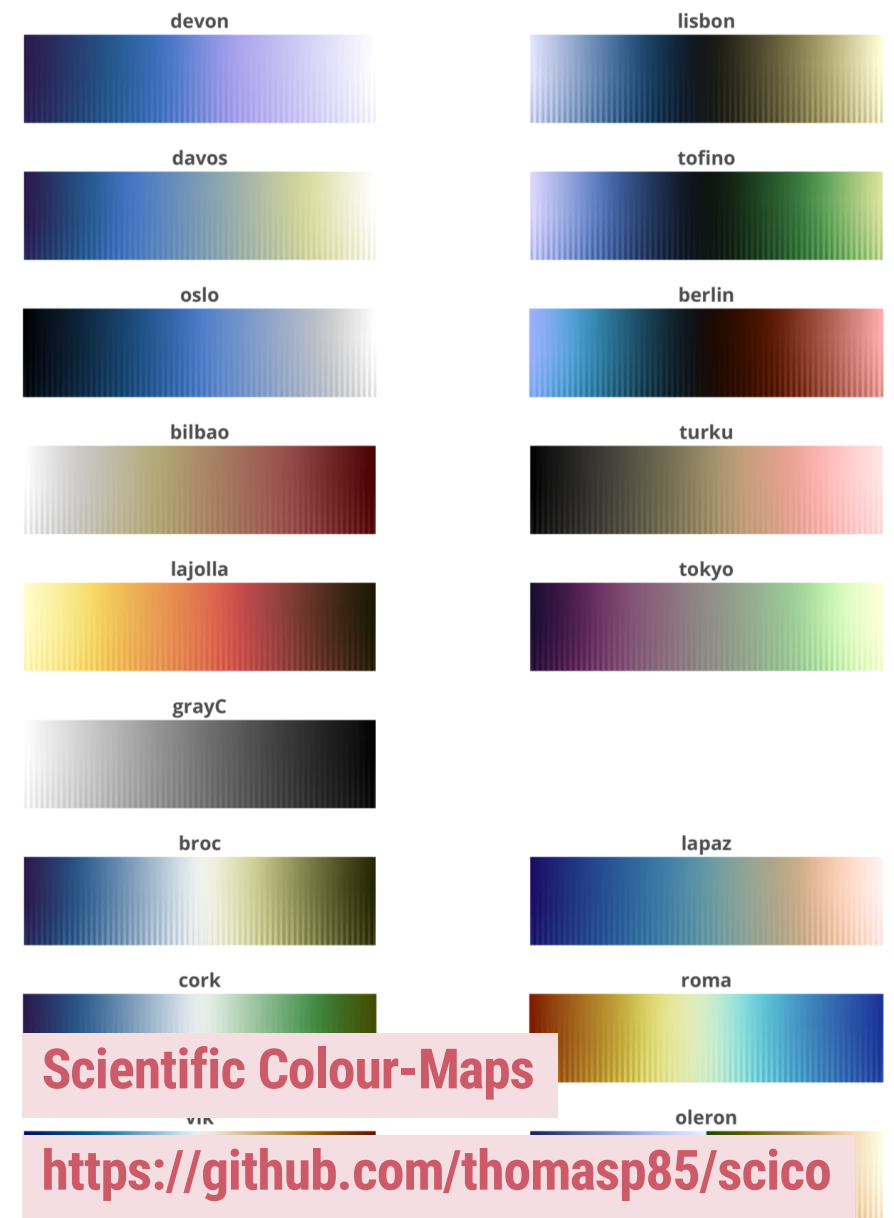
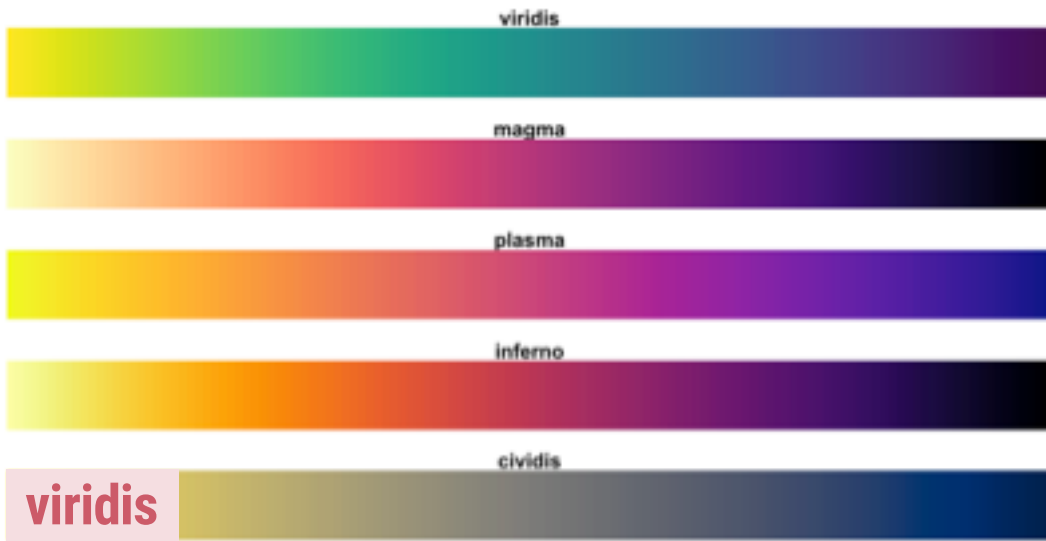

Scientific Colour-Maps

<https://github.com/thomasp85/scico>

James Clifton Thomas
123 Penny Lane
Portland, OR 97211
(888) 555-1212



PROFILE:

A multi-talented, hard-working young man, easy to get along with, dependable, and joyful.

ACCOMPLISHMENTS:

January 2006-present Web designer and developer, working with a professional team of creatives in Portland.

May 2000-January 2006 Pocket Full of Posies Day Care Center. Changed diapers, taught magic and painting, wiped noses, read books to and danced with babies and toddlers. Also coordinated schedules, hired other teachers, and developed programs for children.

Summer 2006 Updated the best-selling book, *The Non-Designer's Web Book* with my mom (Robin Williams) and John Tollett.

1997-2000 Developed and led a ska band called Lead Veins. Designed the web site and coordinated a national tour.

EDUCATION:

2002-2005 Pacific Northwest College of Art, Portland, Oregon: B.A. in Printmaking

1999-2000 Santa Rosa High School, Santa Rosa, California

1997-1998 Santa Fe High School, Santa Fe, New Mexico

1982-1986 Poppy Creek Daycare Center, Santa Rosa, California

PROFESSIONAL AFFILIATIONS:

Grand National Monotype Club, Executive Secretary, 2000-2002

Jerks of Invention, Musicians of Portland, President, 1999-present

Local Organization of Children of Robin Williams, 1982-present

HOBBIES:

Snowboarding, skateboarding, tap dancing, cooking, magic, music (trumpet, drums, vocals, bass guitar), portrait drawing

References available on request.

James Clifton Thomas



123 Penny Lane
Portland, Oregon 97211
(888) 555-1212

Profile

A multi-talented, hard-working young man, easy to get along with, dependable, and joyful.

Accomplishments

2006-present **Web designer and developer**, working with a professional team of creatives in Portland.

2000-2006 **Pocket Full of Posies Day Care Center**. Changed diapers, taught magic and painting, wiped noses, read books to and danced with babies and toddlers. Also coordinated schedules, hired other teachers, and developed programs for children.

Summer 2006 **Updated the best-selling book**, *The Non-Designer's Web Book* with my mom (Robin Williams) and John Tollett.

1997-2000 **Developed and led a ska band** called Lead Veins. Designed the web site and coordinated a national tour.

Education

2002-2005 Pacific Northwest College of Art, Portland, Oregon: **B.A. in Printmaking**

1999-2000 Santa Rosa High School, Santa Rosa, California

1997-1998 Santa Fe High School, Santa Fe, New Mexico

1982-1986 Poppy Creek Daycare Center, Santa Rosa, California

Professional Affiliations

2000-2002 Grand National Monotype Club, Executive Secretary

1999-present Jerks of Invention, Musicians of Portland, President

1982-present Local Organization of Children of Robin Williams

Hobbies

Snowboarding, skateboarding, tap dancing, cooking, magic, music (trumpet, drums, vocals, bass guitar), portrait drawing

Repetition

“Repeat some aspect of the design throughout the entire piece.”

FALL 2004

Jamba Whirl

DISCOVER MORE

• FRESH SQUEEZED •

Start The Day

Bored with breakfast? Skipping it altogether? Wake up to a new way to start your day:

Jamba Juice!

Delicious!

Jamba is the perfect place to pick up that all-important morning meal. First, our fruit-filled products are overflowing with vital vitamins and minerals to give your body the breakfast boost it needs. Even better, you can grab them on the go—and they taste great, too!

New Fantastic Functional Smoothies. Still sleepy? Get Up & Mango™. This new energy smoothie blends brilliant mangos and perky peaches with soymilk, nonfat frozen yogurt and our special Energy Boost™—a potent combination of ginseng, ginkgo biloba, and other fatigue-fighting herbs, as well as four energy-essential B vitamins. Get Up & Mango™ will get you moving—and give you plenty of potassium, calcium and vitamins C and A, as well as 15 grams of protein*.

Want more protein? Our Blue Banana Blast™ smoothie is bursting with blueberries and bananas, plus soymilk, nonfat plain yogurt, nonfat frozen yogurt, and Jamba's Protein Boost™. You get 22 grams of protein, plus lots of dietary fiber, calcium and vitamin D. Drink up!

New Yummy Yogurt Blends. These sweet and creamy creations blend nonfat plain yogurt and soymilk with your favorite fresh fruits and fruit juices. These drinkable yogurts are a good source of protein and an excellent source of calcium and vitamins C and D. Yogurt's "friendly bacteria" helps aid in digestion, too. Choose from Sunrise Strawberry™, Bright Eye & Blueberry™ and Pick-Me-Up Peach™.

Tomorrow morning, don't let the first meal of the day put you to sleep! Go to Jamba—and give yourself a fresh start!

* Nutritional information based on Original size smoothie.

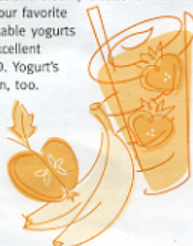

• FUEL FACTS •

Rise and Shine With Breakfast

Your mother was right: You shouldn't skip breakfast.

But eating any old morning meal won't do. To start the day right, you need to feed your body the vitamins and nutrients it craves.

"You don't want to waste calories," explains Suzanne Havala Hobbs, a registered dietitian and member of Jamba's Wellness Advisory Board. "If you load up on empty calories for breakfast, by the end of the day, you're more likely to have missed some important nutrients."

A nutritious breakfast offers a bounty of benefits. For one, you'll have more energy and will probably perform better at work or school. Why? When you wake up in the morning, your body's energy stores are low. After all, you haven't eaten anything in eight to 12 hours. If you don't refuel with breakfast, you'll probably be starved by lunch—and more likely to overeat and make impulsive food choices.

(Continued on back page)

Visit jambajuice.com for a complete list of store locations!

• BEHIND THE BLENDER •

The Secret To Jamba Smoothies

Ever wonder why Jamba smoothies taste so terrific? The secret is in the fruit—and how we pick it.

It starts in the fields. Jamba's suppliers pick produce at the peak of perfection, and within hours, that fruit is "individually quick frozen" to lock in its fresh flavor, juices and nutrients. Soon, it's on its way to Jamba stores, ready to be mixed into one of our splendid smoothies!

Of course, not all fruits are created equal. And when Jamba searches the globe for the best bananas, berries, peaches and more, we're pretty hard to please. We're not only picky about the fruit itself—we insist on a specific variety of strawberry, and each one must adhere to our strict standards for color and flavor—we're also choosy about the people who supply it.

Our suppliers must meet a long list of stringent standards for ensuring quality and food safety. We require vendors to detail all of their quality and safety processes and pass a rigorous third-party audit before we'll even agree to taste-test their fruit. In addition, Jamba officials visit supplier facilities and continue reviewing processes even after a contract is signed. Many of our vendors have been our trusted partners for years.

Why all the fuss? Jamba is committed to providing only the highest quality products to our customers. After all, the better the fruit, the better the smoothie!

FRESH CROP Opening This Fall!

Rancho Cucamonga, California
Ft. Lauderdale, Florida
Charlotte, North Carolina
Honolulu, Hawaii
Fifth Avenue, New York
Orland Park, Illinois

• JAMBATUDE •

Spreading The Jamba Spirit

Jamba General Manager Ray Sterling is a big believer in supporting the local community. So when Ray, who manages the Jamba store at 9th and Irving streets in San Francisco, saw that the 2004 AIDS Walk San Francisco fundraising event was approaching, he sprang into action.

Ray volunteered to captain a team of walkers and, with the help of the Jamba's Northern California marketing department, quickly spread the word about the event to all the stores in Northern California. His goal: Raise \$10,000 for AIDS Walk, which benefits the San Francisco AIDS Foundation and other organizations that provide services, support and education to AIDS patients.

His enthusiasm turned out to be contagious. On July 18, the day of the walk, he found himself leading a team of more than 40 people, including Jamba team members, customers and friends and family. Two team members donned BananaMan costumes, and the rest of the team sported bright yellow Jamba t-shirts as they walked 6.2 miles through Golden Gate Park. Total money raised: \$16,019.

"I think it's so important to support the local community," Ray explains. **"This is a big event in San Francisco, and the money goes to help people and children right here. I felt it was essential for Jamba to be a part of it."**

The AIDS Walk isn't the only community project Ray has been involved with since joining Jamba two-and-a-half years ago. He also works with a local chapter of The Arc, an organization that helps people with developmental disabilities. Through The Arc, Ray has hired several people with disabilities to work for him at Jamba. For his efforts, he was recognized as an "Employer of the Year" last year by the San Francisco Mayor's Committee for Employment of Persons with Disabilities.

"Ray exemplifies everything that Jamba stands for," says Gail DiSantis, a Jamba District Manager for San Francisco and Ray's boss. "He's friendly, fun and energetic, and when it comes to helping the community, he doesn't just talk. He's a doer."



Alignment

“Every item should have a visual connection with something else on the page.”

Example 6: Value of a resistor in an electrical circuit.

Find the value of a resistor in an electrical circuit which will dissipate the charge to 1 percent of its original value within one twentieth of a second after the switch is closed.

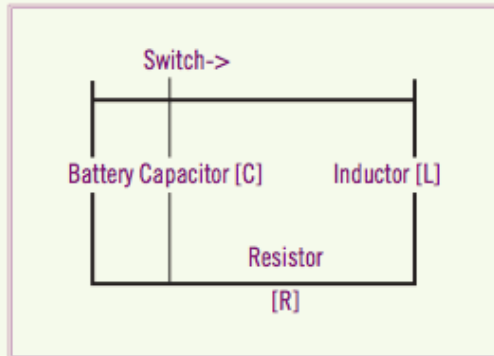

$q_0 = 9$ volts
 $q(t) = 0.09$ volts
 $t = 0.05$ seconds
 $L = 8$ henrys
 $C = 0.0001$ farads
 $R = 300$ ohms
 $q(t) = 0.253889$

$1/[L * C]$	1250
$[R / (2 * L)]^2$	351.5625
$\text{SQRT}(B15 - B16)$	29.973947
$\text{COS}(T * B17)$	0.07203653
$-R * T / (2 * L)$	-0.9375
$Q_0 + \text{EXP}(B 19)$	3.52445064

Example 6: Value of a resistor in an electrical circuit.

Find the value of a resistor in an electrical circuit which will dissipate the charge to 1 percent of its original value within one twentieth of a second after the switch is closed.

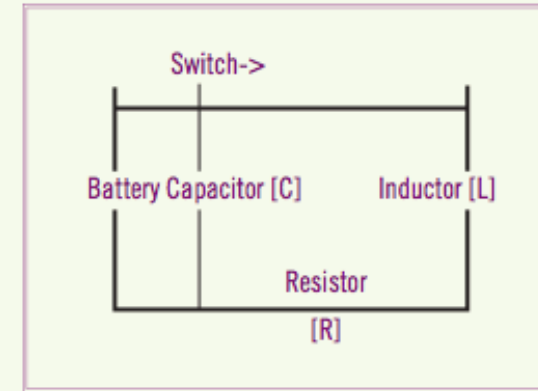

$q_0 = 9$ volts
 $q(t) = 0.09$ volts
 $t = 0.05$ seconds
 $L = 8$ henrys
 $C = 0.0001$ farads
 $R = 300$ ohms
 $q(t) = 0.253889$

$1/[L * C]$	1250
$[R / (2 * L)]^2$	351.5625
$\text{SQRT}(B15 - B16)$	29.973947
$\text{COS}(T * B17)$	0.07203653
$-R * T / (2 * L)$	-0.9375
$Q_0 + \text{EXP}(B 19)$	3.52445064

Fewer/Less

The Controversy: Some usage dictionaries state that fewer and less can be used synonymously while others say that there is a distinct difference in the usage between the two. Fewer cannot be used in place of less, but can less be used in place of fewer?

The Traditional Rule: Fewer refers to number among things that are counted, or readily distinguishable units (fewer people, ships, houses.) Less refers to quantity or amount among things that are measured (less sugar, time, energy).

History: The rule first originated in 1770 as a rule on less, "this word is commonly used in speaking of a number; where fewer would do better. Essentially less has been used of countables in English just about as long as there has been a written English language. After about 900 years Robert Baker opined that fewer might be more elegant and proper. Almost every usage writer since Baker has followed Baker's lead, and generations of English teachers have swelled the chorus. "No fewer than a hundred appears to me not only more elegant than no less than a hundred, but strictly more proper." - Baker 1770

Consensus: A substantial majority of panel members advocates retaining this distinction between less and fewer. The general consensus favors the traditional rule that fewer refers to countable things while less refers to things measured, though strong forces are pushing against it.

Examples:

"However fewer and fewer writers observe it, so the distinction is becoming less and less." -Vermont Royster

"...Dudek's car has fewer than 600 miles on the odometer." - Rick Reilly

"...has never gained fewer than 1,222 yards in a season." -Rick Telander

"The odometer showed less than ten thousand miles." - E.L. Doctoerow

"I was never in Europe for less than fourteen months at a time." - James Thurber

not very important history

HISPANIC AWARENESS FILM SERIES

HAROLD B. LEE LIBRARY

Tortilla Soup (2001)

**WEDNESDAY
OCTOBER 8
5:00PM**

LEE LIBRARY AUDITORIUM

1080 HBLL

Proximity

“Group related items together.”

Ralph Roister Doister

(717) 555-1212

Mermaid Tavern

916 Bread Street

London, NM

Mermaid Tavern

Ralph Roister Doister

916 Bread Street

London, NM

(717) 555-1212

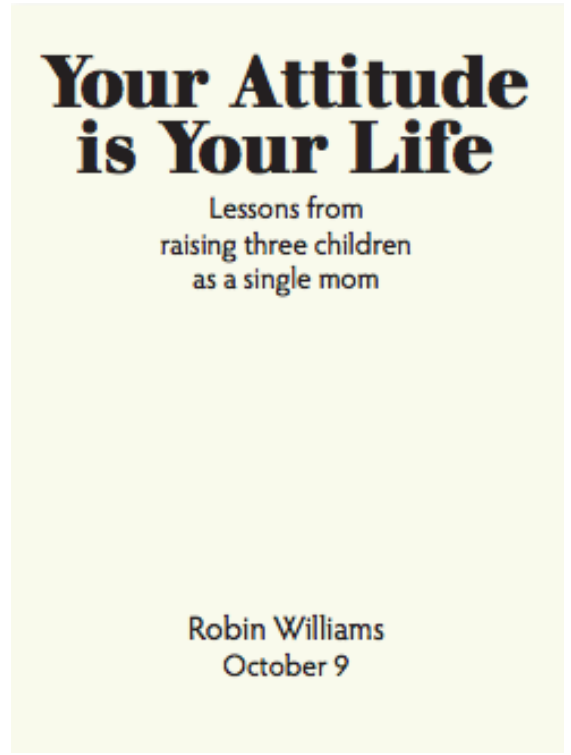
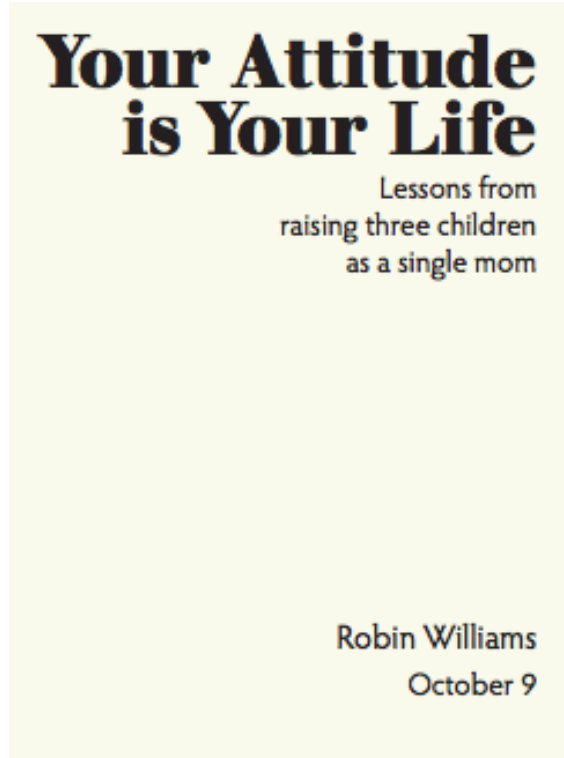
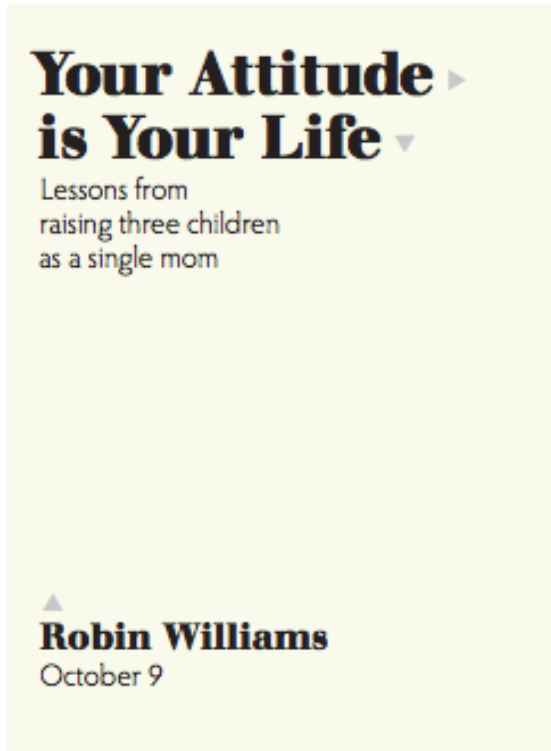
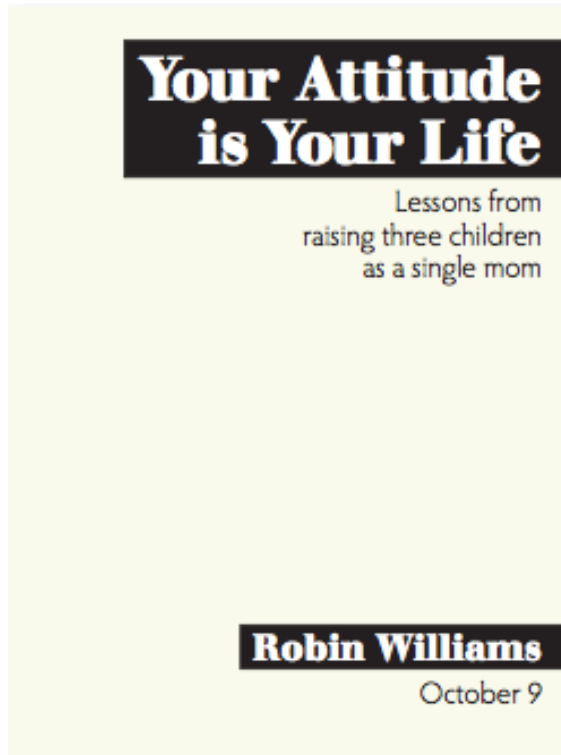

Contrast

Repetition

Alignment

Proximity

 Take a sad plot
and make it CRAPier 

By default, R graphics violate CRAP

```
plot(mtcars$wt, mtcars$mpg,  
      main = "Here's a title")
```

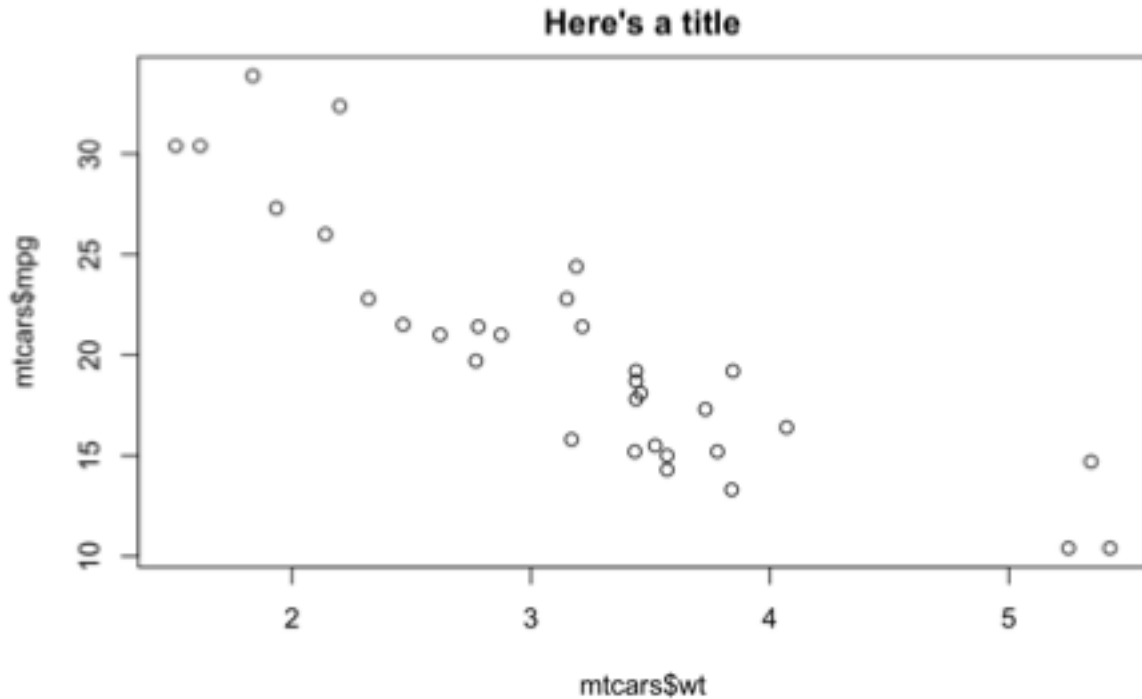

```
ggplot(mtcars, aes(x = wt, y = mpg)) +  
  geom_point() +  
  labs(title = "Here's a title")
```

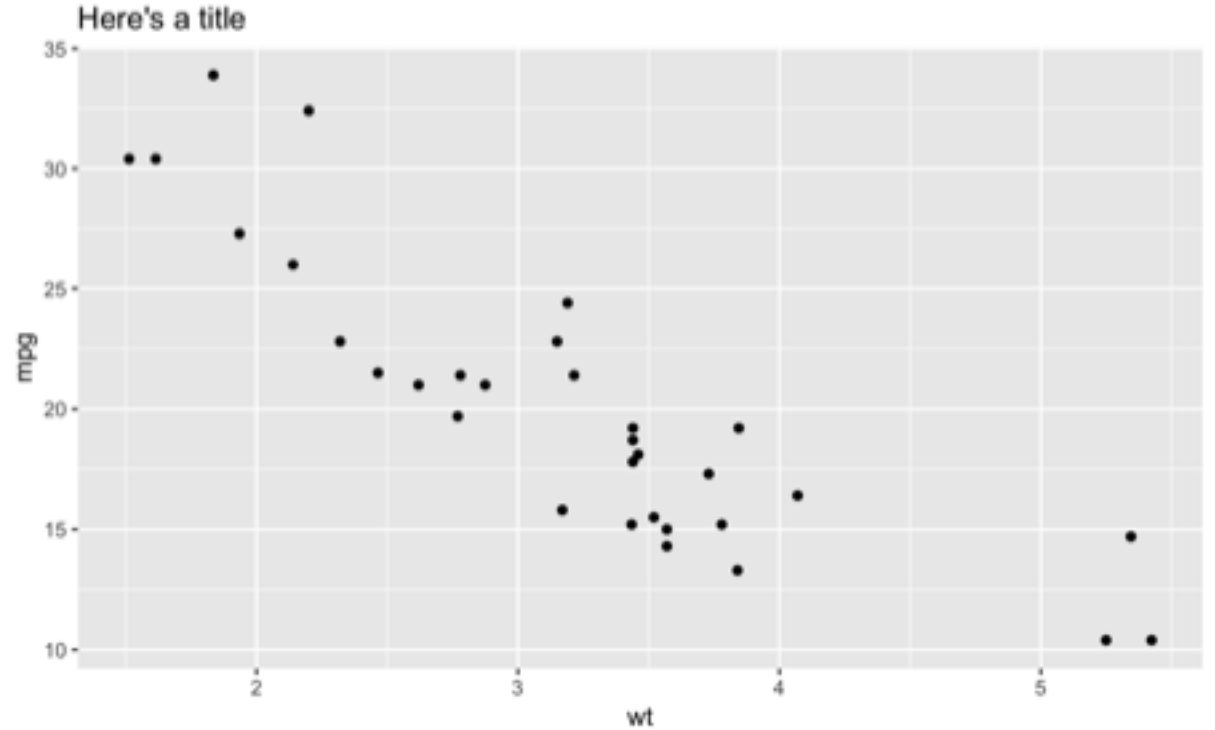

With ggplot's `theme()` and other functions, we can make beautiful CRAPy figures automatically with R

You can also do this in base R, but I find ggplot's paradigm more intuitive

talks.andrewheiss.com/utah-rug-dataviz/

Moral of the story

Graphics are essential for telling stories and gaining insight

Design principles (CRAP) make graphics better understandable

R + ggplot can follow CRAP and make beautiful, insightful graphics